

JACK

China No.1



Electronic Lockstitch Buttonholing



JK-T1790B



Jack Wechat



Jack Sewing
Machine Co.,Ltd.

JACK SEWING MACHINE CO.,LTD.

No. 15 Airport South Road, Jiaojiang District, Taizhou, Zhejiang, PRC
TEL: 0086-576-88177782 88177767
FAX: 0086-576-88177787

E-mail: sales@chinajack.com
www.chinajack.com

JK-T1790B

JK-T1790B is driven by AC servo motor, with features such as low vibration, low noise, high efficiency and excellent sewing quality, which makes the machine capable for various kinds of knitting and woven fabrics such as shirt, T-shirt, and uniform.



Advantages



1 Intelligent System, High Speed and High Efficiency

LCD touch screen, fast reaction, simple operation

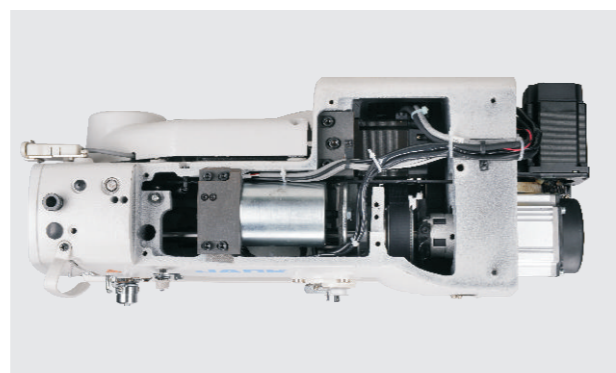

2 Closed Loop Motor, High Efficiency and Stable(Only for DAHAO Electronic Control)

Using step motor in feeding, needle and presser foot makes the sewing more stable

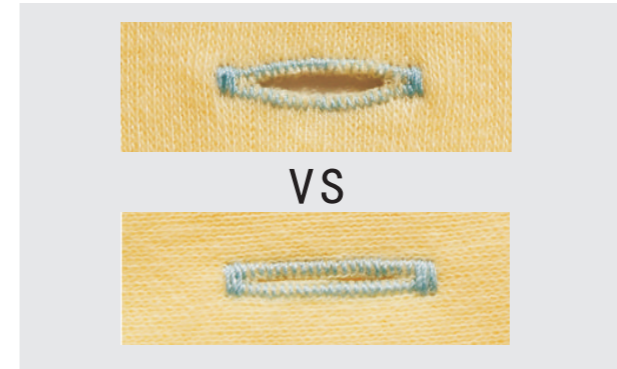

3 Basting Stitch Function, Beautiful Stitch

Especially use for elastic fabric, basting stitch and buttonholing can complete at the same time.

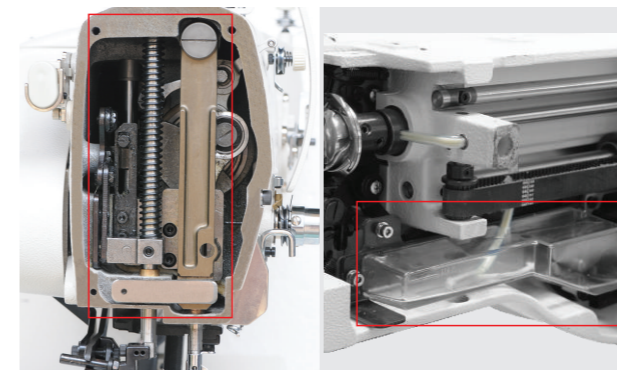

5 Dry-head System, Semi-dry Hook

Dry-head design makes the sewing clean



4 Cooling System, Long Durability



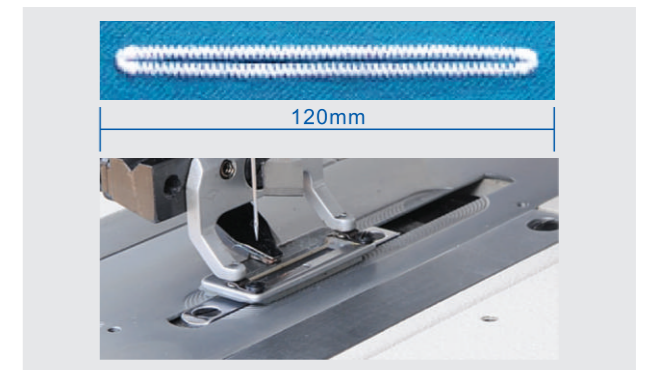







The cooling fan greatly decreases the temperature of motor, lengthen the lifetime of machine.



6 Multi-Cutting Function, Perfect for Different Holing Size

Different button holing size (JK-T1790B max. 120mm) can be operated without changing the cutting knife.

Technical Parameters

											
	(mm)					(mm)	(S.p.m)	(mm)		(mm)	NW / GW (kg)
JK-T1790BS-1	25×4	DPX5 12#	1	1/4"~3/4"	2	0.2~2.5	220V	17	4200	780×390×830	56/77
JK-T1790BS-2	35×5	DPX5 12#	1	1/4"~1"	2	0.2~2.5	220V	17	4200	780×390×830	56/77
JK-T1790BS-3	41×5	DPX5 12#	1	1/4"~1 1/4"	2	0.2~2.5	220V	17	4200	780×390×830	56/77
JK-T1791BS	70×5	DPX5 12#	1	1/4"~1 1/4"	2	0.2~2.5	220V	17	4200	780×390×830	56/77
JK-T1792BS	120×5	DPX5 12#	1	1/4"~1 1/4"	2	0.2~2.5	220V	17	4200	780×390×830	56/77
JK-T1790BK-1	25×4	DPX5KN 11#	1	1/4"~3/4"	2	0.2~2.5	220V	17	4200	780×390×830	56/77
JK-T1790BK-2	35×5	DPX5KN 11#	1	1/4"~1"	2	0.2~2.5	220V	17	4200	780×390×830	56/77
JK-T1790BK-3	41×5	DPX5KN 11#	1	1/4"~1 1/4"	2	0.2~2.5	220V	17	4200	780×390×830	56/77
JK-T1791BK	70×5	DPX5KN 11#	1	1/4"~1 1/4"	2	0.2~2.5	220V	17	4200	780×390×830	56/77
JK-T1792BK	120×5	DPX5KN 11#	1	1/4"~1 1/4"	2	0.2~2.5	220V	17	4200	780×390×830	56/77

Notice: S is for normal fabrics, K is for knitting fabrics. JK-T1790BS-1-D, D is for DAHAO electronic control